

**RAHO Series A**

Horizontal High Performance Concealed

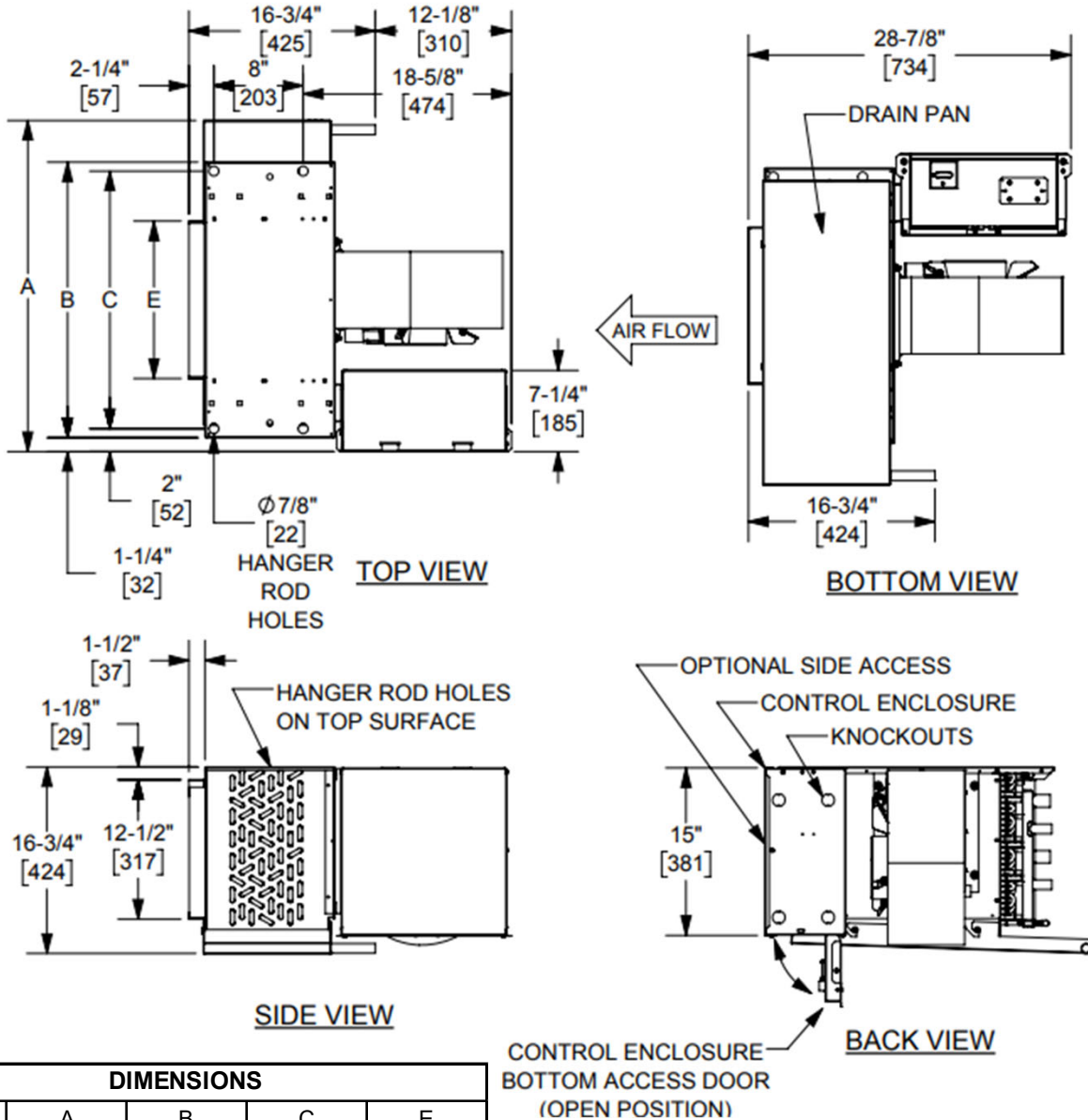

DIMENSIONS				
UNIT SIZE	A	B	C	E
06	34-7/8" [886]	24-5/8" [721]	23-1/8" [587]	14" [356]
08	39-7/8" [1013]	29-5/8" [737]	28-1/8" [714]	19" [483]
10	43-7/8" [1114]	33-5/8" [838]	32-1/8" [816]	23" [584]
12	48-7/8" [1241]	38-5/8" [965]	37-1/8" [943]	28" [711]
14	53-7/8" [1368]	43-5/8" [1092]	42-1/8" [1070]	33" [838]
16	58-7/8" [1495]	48-5/8" [1219]	47-1/8" [1197]	38" [965]
18	63-7/8" [1622]	53-5/8" [1346]	52-1/8" [1324]	43" [1092]
20	67-7/8" [1724]	57-5/8" [1448]	56-1/8" [1426]	47" [1194]

- NOTES:**
1. All dimensions in Inches [millimeters]. All dimensions  $\pm 1/4"$  [6mm]. Metric values are soft conversion.
  2. Right hand unit shown, Left hand unit opposite.
  3. Standard control enclosure is mounted on unit side opposite cooling coil connections and includes (4) knockouts on (2) sides. Provide sufficient clearance to access electrical controls and comply with applicable codes and ordinances.

**RAHR/RAHO Series A**

Horizontal High Performance Concealed & Concealed Plenum Field Connections (2-pipe Coil)

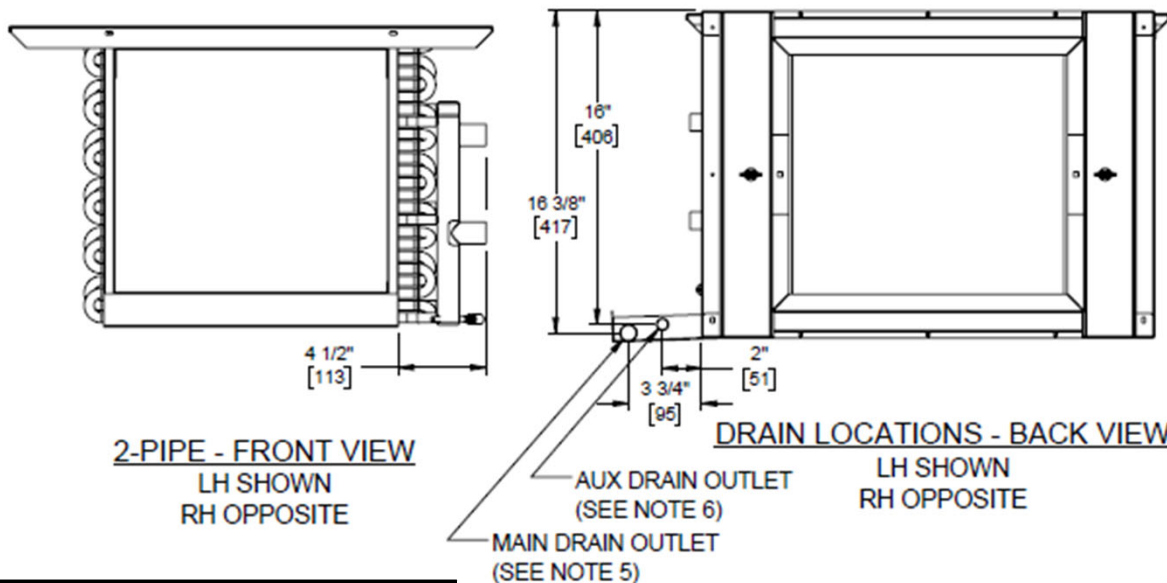
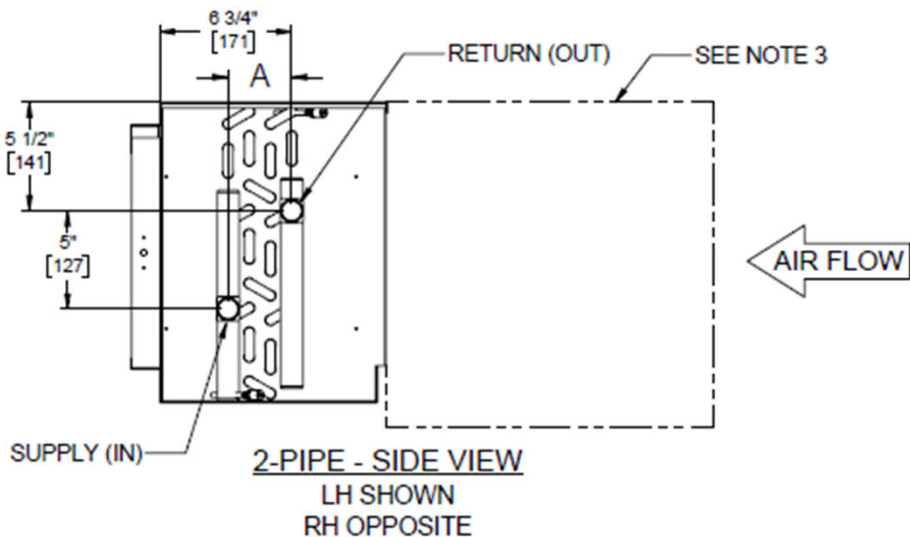

2

Unit Type	Coil Rows	A	
		(1/2" Coil)	(3/8" Coil)
2 Pipe Heating	1	1-1/8" [29]	7/8" [22]
	2	1-1/8" [29]	7/8" [22]
	3	2-1/8" [54]	1-3/4" [44]
	4	3-1/4" [83]	2-5/8" [67]
2 Pipe Cooling	3	2-1/8" [54]	1-3/4" [44]
	4	3-1/4" [83]	2-5/8" [67]
	6	5-3/8" [137]	4-3/8" [86]

**NOTES:**

1. All dimensions are inches [millimeters] All dimensions +/-1/2 [13mm]. Metric values are soft conversion.
2. All drawings subject to change without notice.
3. Model "RAHR" unit shown, typical for model "RAHO" units. Connections shown are internal on "RAHC" units.
4. Connection Size: See page 10 for Coil Connections.
5. Standard externally foam coated galvanize steel drain pan has 7/8" ODM copper outlet. Stainless steel drain pan has 3/4" MPT galvanize steel outlet.
6. Aux. drain outlet is 5/8" ODM copper or 3/8" MPT galvanize steel respectively.
7. Single Row/Single Circuit headers are vertical (Horizontal Distance is 0")

**RAHR/RAHO Series A**

Horizontal High Performance Concealed & Concealed Plenum Field Connections (4-Pipe Reheat 1/2" Coil)

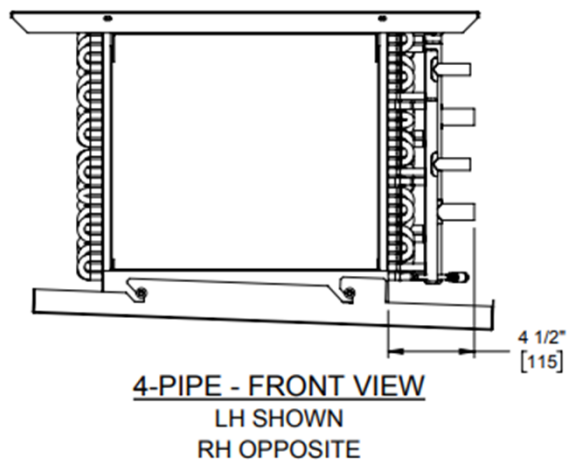
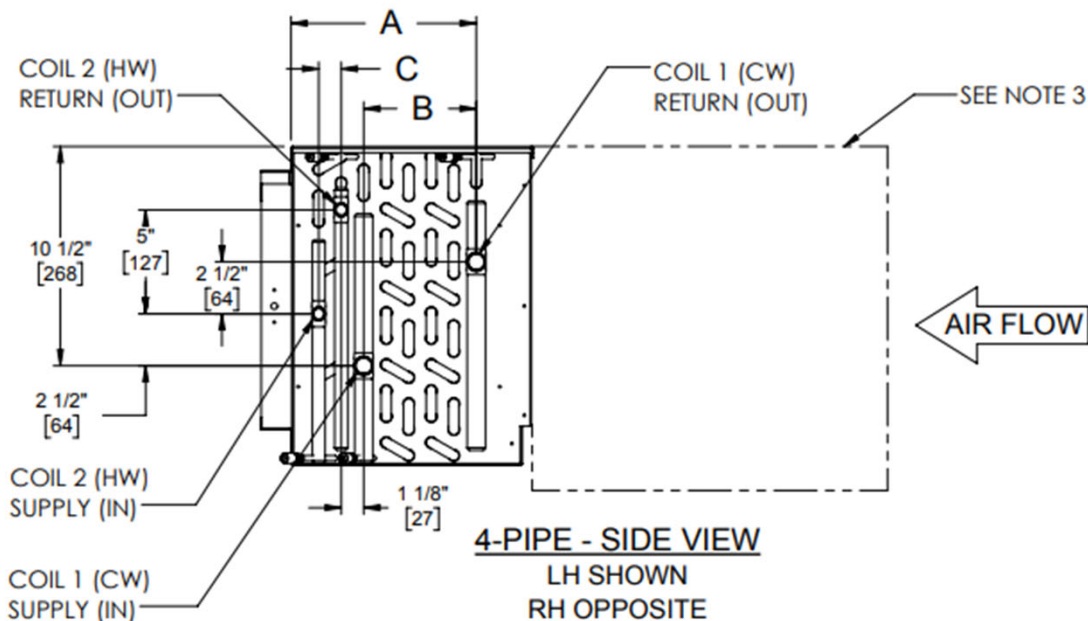

Unit Type - 4 Pipe in Re-Heat Position				
Coil 1 CW Rows	Coil 2 HW Rows	1/2" Coil		
		A	B	C
3	1	6-3/4" [171]	1-5/8" [41]	1-1/4" [32]
3	2	6-3/4" [171]	1-7/8" [48]	1-1/8" [29]
3	3	6-3/4" [171]	2" [51]	2-1/4" [57]
4	1	6-3/4" [171]	3" [76]	1-1/4" [32]
4	2	6-3/4" [171]	3" [76]	1-1/8" [29]
3	4	8-7/8" [225]	2" [51]	3-1/4" [83]
4	3	8-7/8" [225]	3-1/4" [83]	2" [51]
4	4	8-7/8" [225]	3-1/4" [83]	3-1/4" [83]
6	1	8-7/8" [225]	5" [127]	1-1/8" [29]
6	2	8-7/8" [225]	5-1/4" [133]	1-1/8" [29]

**NOTES:**

1. All dimensions are inches [millimeters] All dimensions +/-1/2 [13mm]. Metric values are soft conversion.
2. All drawings subject to change without notice.
3. Model "RAHR" unit shown, typical for model "RAHO" units. Connections shown are internal on "RAHC" units.
4. Connection Size: See page 10 for Coil Connections.
5. Standard externally foam coated galvanize steel drain pan has 7/8" ODM copper outlet. Stainless steel drain pan has 3/4" MPT galvanize steel outlet.
6. Aux. drain outlet is 5/8" ODM copper or 3/8" MPT galvanized steel respectively.
7. Single Row/Single Circuit headers are vertical (Horizontal Distance is 0")

**RAHR/RAHO Series A**

Horizontal High Performance Concealed & Concealed Plenum Field Connections (4-Pipe Reheat 3/8" Coil)

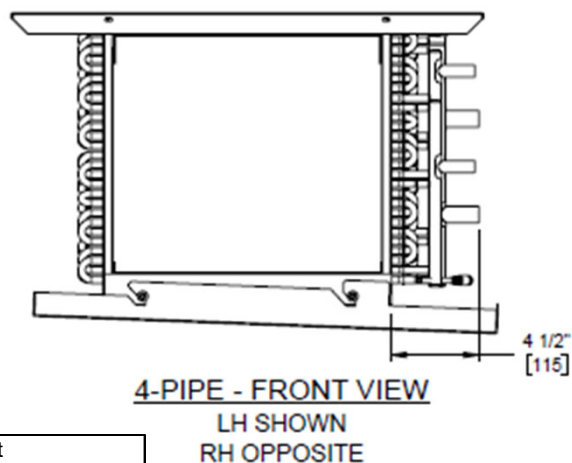
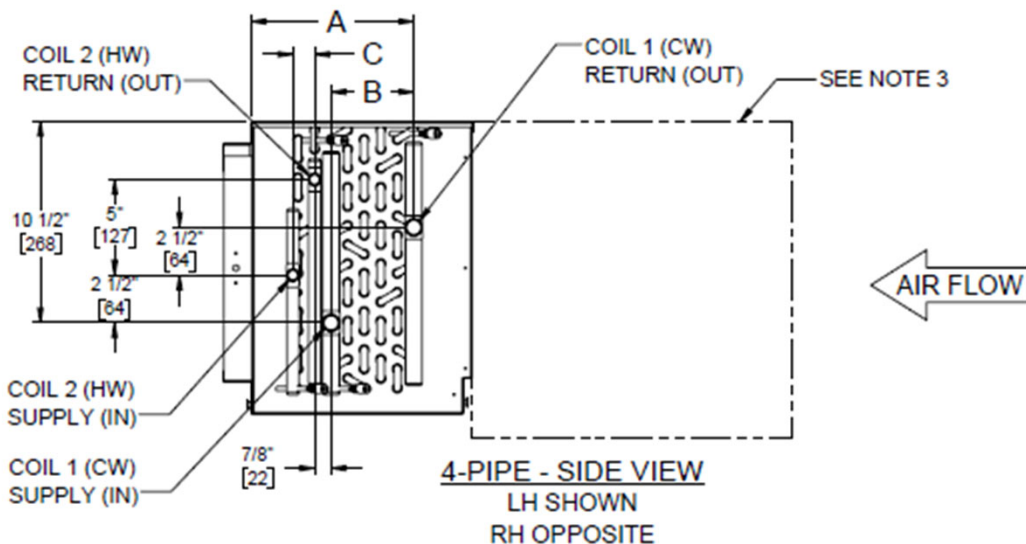

Unit Type - 4 Pipe Re-Heat				
Coil 1 CW Rows	Coil 2 HW Rows	3/8" Coil		
		A	B	C
3	1	6-3/4" [171]	1-1/2" [38]	1" [25]
3	2	6-3/4" [171]	1-3/8" [35]	1" [25]
3	3	6-3/4" [171]	1-3/4" [44]	1-1/2" [38]
4	1	6-3/4" [171]	1-3/4" [44]	1" [25]
4	2	6-3/4" [171]	2-1/4" [57]	1" [25]
3	4	8-1/2" [216]	1-1/2" [38]	2-5/8" [67]
4	3	8-1/2" [216]	2-5/8" [67]	1-1/2" [38]
4	4	8-1/2" [216]	2-5/8" [67]	2-1/4" [57]
6	1	8-1/2" [216]	3-1/2" [89]	1" [25]
6	2	8-1/2" [216]	4" [102]	1" [25]

**NOTES:**

1. All dimensions are inches [millimeters] All dimensions +/-1/2 [13mm]. Metric values are soft conversion.
2. All drawings subject to change without notice.
3. Model "RAHR" unit shown, typical for model "RAHO" units. Connections shown are internal on "RAHC" units.
4. Connection Size: See page 10 for Coil Connections.
5. Standard externally foam coated galvanize steel drain pan has 7/8" ODM copper outlet. Stainless steel drain pan has 3/4" MPT galvanize steel outlet.
6. Aux. drain outlet is 5/8" ODM copper or 3/8" MPT galvanized steel respectively.
7. Single Row/Single Circuit headers are vertical (Horizontal Distance is 0")

**RAHR/RAHO Series A**

Horizontal High Performance Concealed & Concealed Plenum Field Connections (4-Pipe Preheat 1/2" Coil)

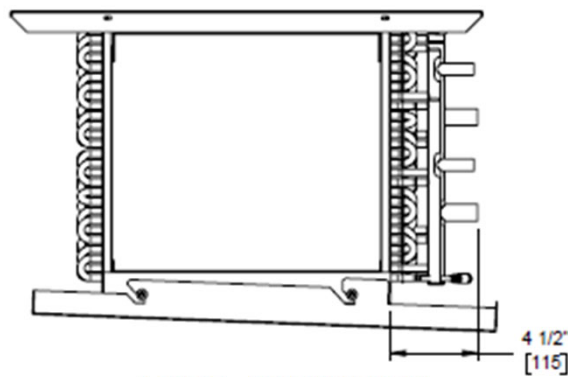
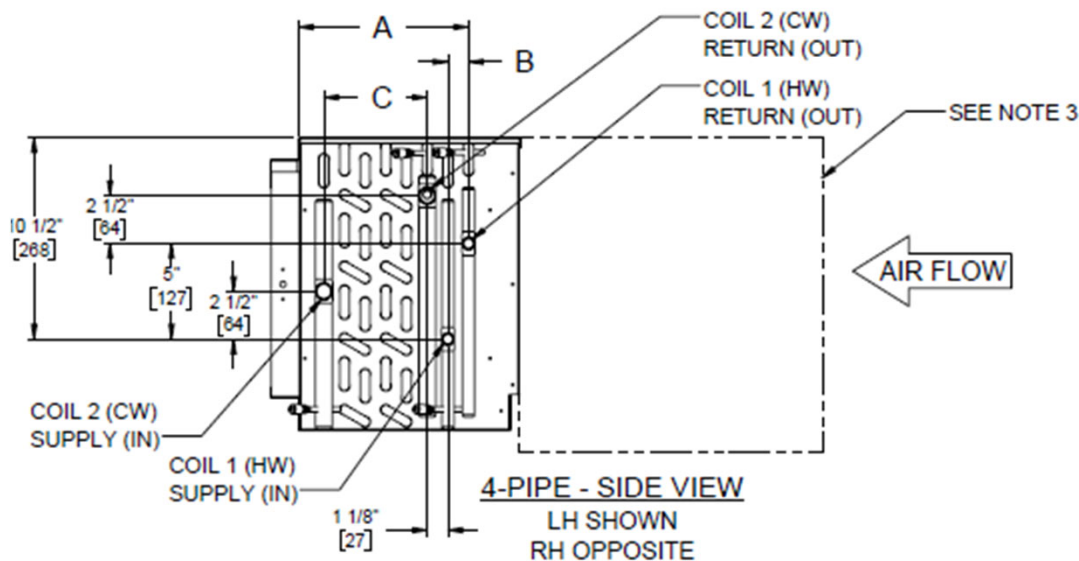

Unit Type - 4 Pipe Pre-Heat				
Coil 1 HW Rows	Coil 2 CW Rows	1/2" Coil		
		A	B	C
1	3	7-5/8" [194]	1-1/8" [29]	1-5/8" [41]
1	4	7-5/8" [194]	1-1/8" [29]	2-1/2" [64]
2	3	6-3/4" [171]	1-1/8" [29]	2-1/8" [54]
2	4	6-3/4" [171]	1-1/8" [29]	3-1/8" [79]
3	3	6-3/4" [171]	2-1/8" [54]	2" [51]
1	6	9-5/8" [244]	1-1/8" [29]	4-3/4" [121]
2	6	8-7/8" [225]	1-1/8" [29]	5-1/4" [133]
3	4	8-7/8" [225]	2-1/8" [54]	3-1/8" [79]
4	3	8-7/8" [225]	3-1/4" [83]	2-1/8" [54]
4	4	8-7/8" [225]	3-1/4" [83]	3-1/8" [79]

**NOTES:**

1. All dimensions are inches [millimeters] All dimensions +/-1/2 [13mm]. Metric values are soft conversion.
2. All drawings subject to change without notice.
3. Model "RAHR" unit shown, typical for model "RAHO" units. Connections shown are internal on "RAHC" units.
4. Connection Size: See page 10 for Coil Connections.
5. Standard externally foam coated galvanize steel drain pan has 7/8" ODM copper outlet. Stainless steel drain pan has 3/4" MPT galvanize steel outlet.
6. Aux. drain outlet is 5/8" ODM copper or 3/8" MPT galvanized steel respectively.
7. Single Row/Single Circuit headers are vertical (Horizontal Distance is 0")

**RAHR/RAHO Series A**

Horizontal High Performance Concealed & Concealed Plenum Field Connections (4-Pipe Preheat 3/8" Coil)

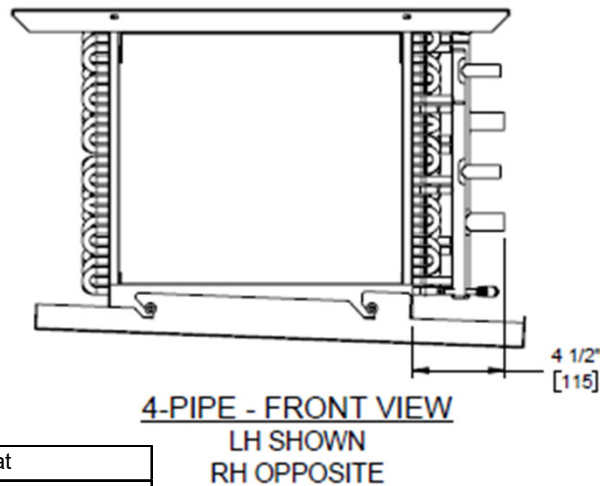
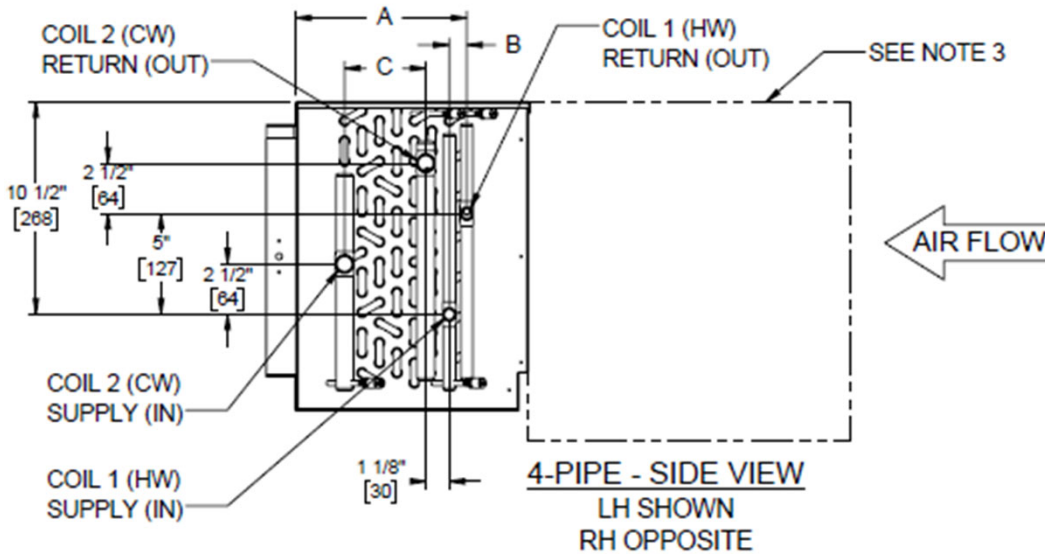

Unit Type - 4 Pipe Pre-Heat				
Coil 1 HW Rows	Coil 2 CW Rows	3/8" Coil		
		A	B	C
1	3	7-1/2" [191]	1" [25]	1-1/2" [38]
1	4	7-1/2" [191]	1" [25]	1-3/4" [44]
2	3	6-3/4" [171]	1" [25]	1-1/2" [38]
2	4	6-3/4" [171]	1" [25]	2" [51]
3	3	6-3/4" [171]	1-3/4" [44]	1-1/2" [38]
1	6	9-1/4" [235]	1" [25]	3-1/2" [89]
2	6	8-1/2" [216]	1" [25]	3-3/4" [95]
3	4	8-1/2" [216]	1-3/4" [44]	2-1/4" [57]
4	3	8-1/2" [216]	2-5/8" [67]	1-1/2" [38]
4	4	8-1/2" [216]	2-5/8" [67]	2-1/4" [57]

**NOTES:**

1. All dimensions are inches [millimeters] All dimensions +/-1/2 [13mm]. Metric values are soft conversion.
2. All drawings subject to change without notice.
3. Model "RAHR" unit shown, typical for model "RAHO" units. Connections shown are internal on "RAHC" units.
4. Connection Size: See page 10 for Coil Connections.
5. Standard externally foam coated galvanize steel drain pan has 7/8" ODM copper outlet. Stainless steel drain pan has 3/4" MPT galvanize steel outlet.
6. Aux. drain outlet is 5/8" ODM copper or 3/8" MPT galvanized steel respectively.
7. Single Row/Single Circuit headers are vertical (Horizontal Distance is 0")

**RAHR/RAHO Series A**

Horizontal High Performance Concealed & Concealed Plenum Field Connections (2-Pipe DX Coil)

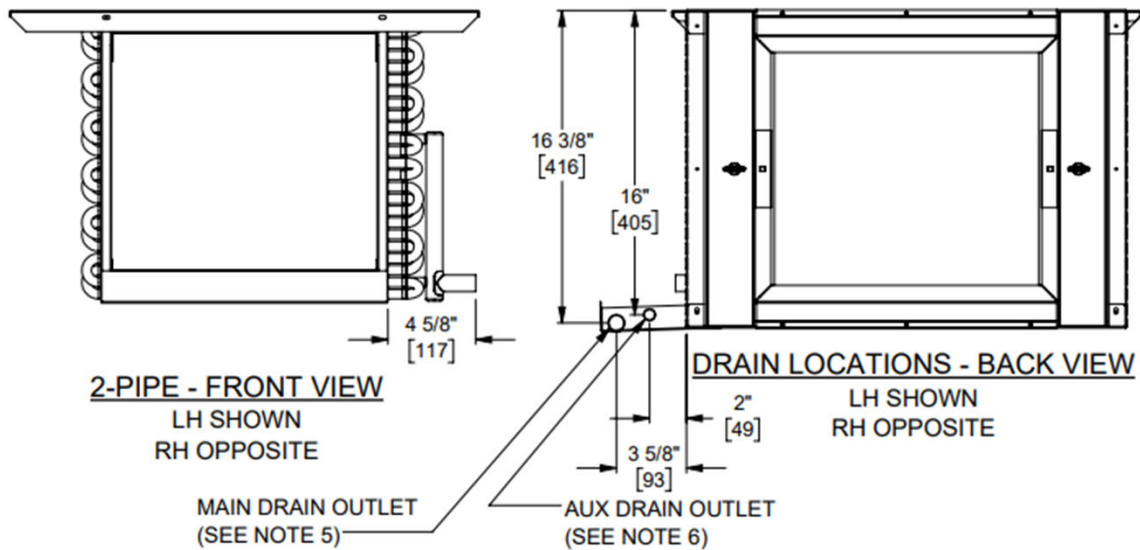
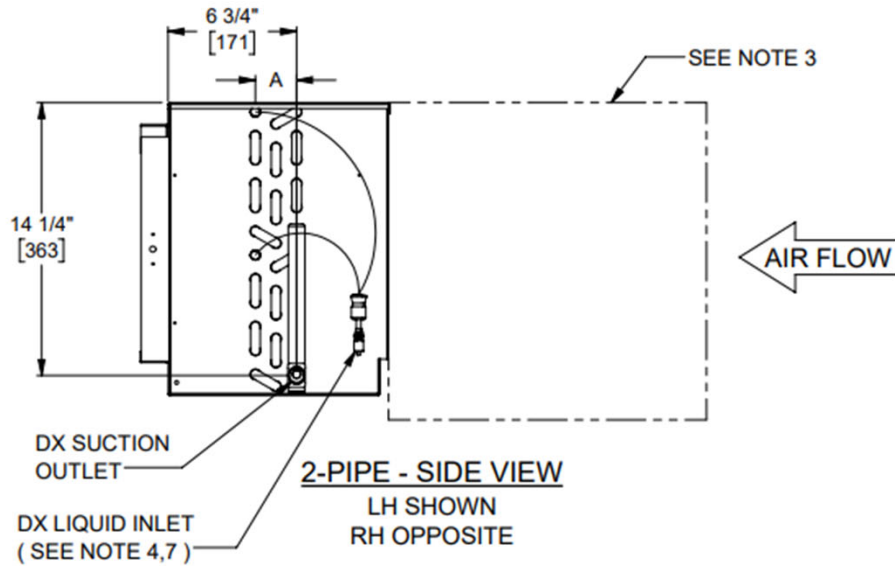

Unit Type - 2 Pipe	
Coil 1 DX Rows	1/2" Coil A
3	2-1/8" [55]
4	3-1/4" [82]
6	5-3/8" [137]

**NOTES:**

1. All dimensions are inches [millimeters]. All dimensions +/-1/2 [13mm]. Metric values are soft conversion.
2. All drawings subject to change without notice.
3. Model "RAHR" unit shown, typical for model "RAHO" units. Connections shown are internal on "RAHC" units.
4. Connection Size: See Page 10 Coil Connections.
5. Standard externally foam coated galvanize steel drain pan has 7/8" ODM copper outlet. Stainless steel drain pan has 3/4" MPT galvanize steel outlet.
6. Aux. drain outlet is 5/8" ODM copper or 3/8" MPT galvanized steel respectively.
7. Liquid Inlet arrangement may vary.

**RAHR/RAHO Series A**

Horizontal High Performance Concealed & Concealed Plenum Field Connections (4-Pipe DX Coil & HW Coil Re-Heat)

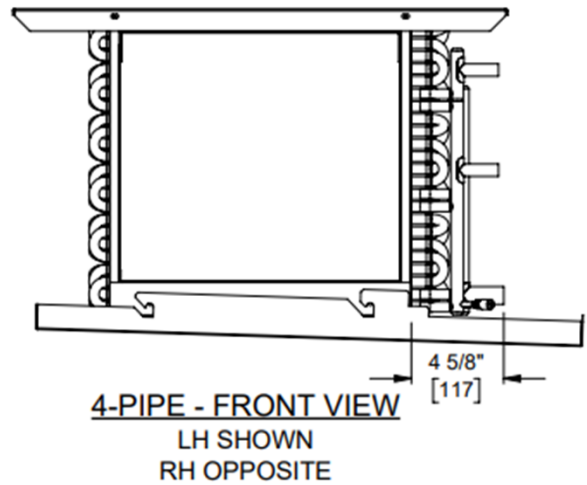
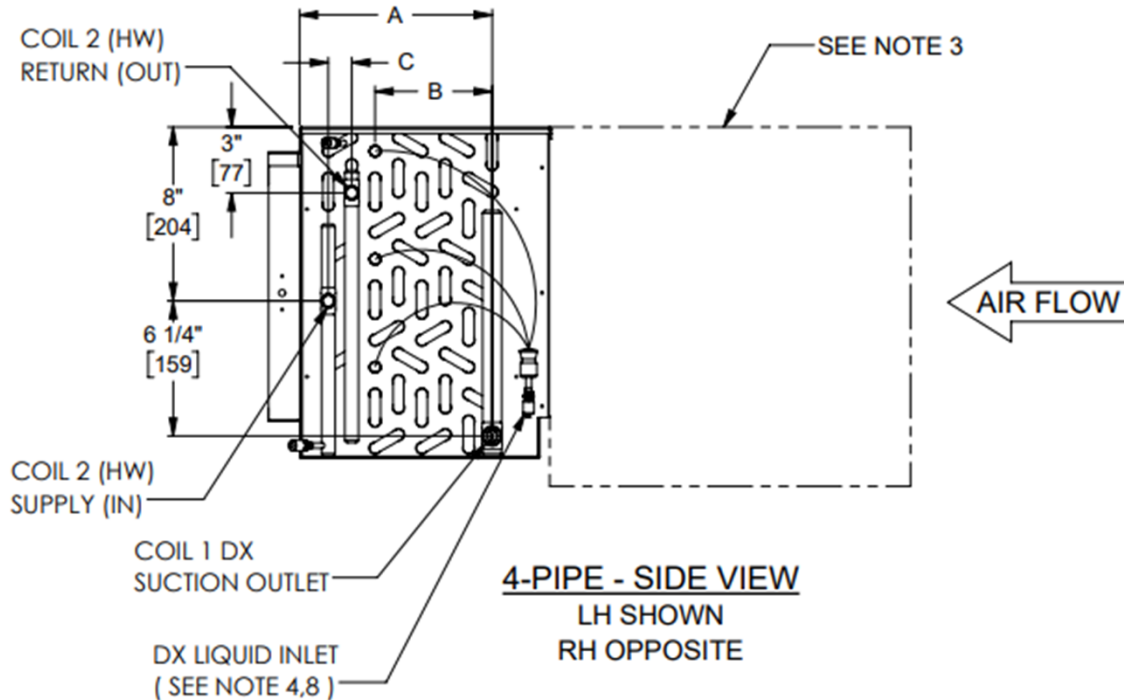

Coil 1 DX Rows	Coil 2 HW Rows	1/2" Coil		
		A	B	C
3	1	6-3/4" [171]	2-1/8" [52]	7/8" [22]
3	2	6-3/4" [171]	2-1/8" [52]	1-1/8" [29]
3	3	6-3/4" [171]	2-1/8" [52]	2-1/8" [52]
4	1	6-3/4" [171]	3-1/4" [83]	1" [25]
4	2	6-3/4" [171]	3-1/4" [83]	1" [25]
3	4	8-7/8" [225]	2-1/8" [52]	3-1/4" [83]
4	3	8-7/8" [225]	3-1/4" [83]	2-1/4" [54]
4	4	8-7/8" [225]	3-1/4" [83]	3-1/4" [83]
6	1	8-7/8" [225]	5-1/2" [140]	7/8" [22]
6	2	8-7/8" [225]	5-1/2" [140]	1-1/8" [29]

- NOTES:
1. All dimensions are inches [millimeters]. All dimensions +/-1/2 [13mm]. Metric values are soft conversion.
  2. All drawings subject to change without notice.
  3. Model "RAHR" unit shown, typical for model "RAHO" units. Connections shown are internal on "RAHC" units.
  4. Connection Size: See Page 10 Coil Connections.
  5. Standard externally foam coated galvanize steel drain pan has 7/8" ODM copper outlet. Stainless steel drain pan has 3/4" MPT galvanize steel outlet.
  6. Aux. drain outlet is 5/8" ODM copper or 3/8" MPT galvanized steel respectively.
  7. Liquid Inlet arrangement may vary.



**RAHR/RAHO Series A**

Horizontal High Performance Concealed & Concealed Plenum Field Connections (2-Pipe EH & DX Coil Pre-Heat)

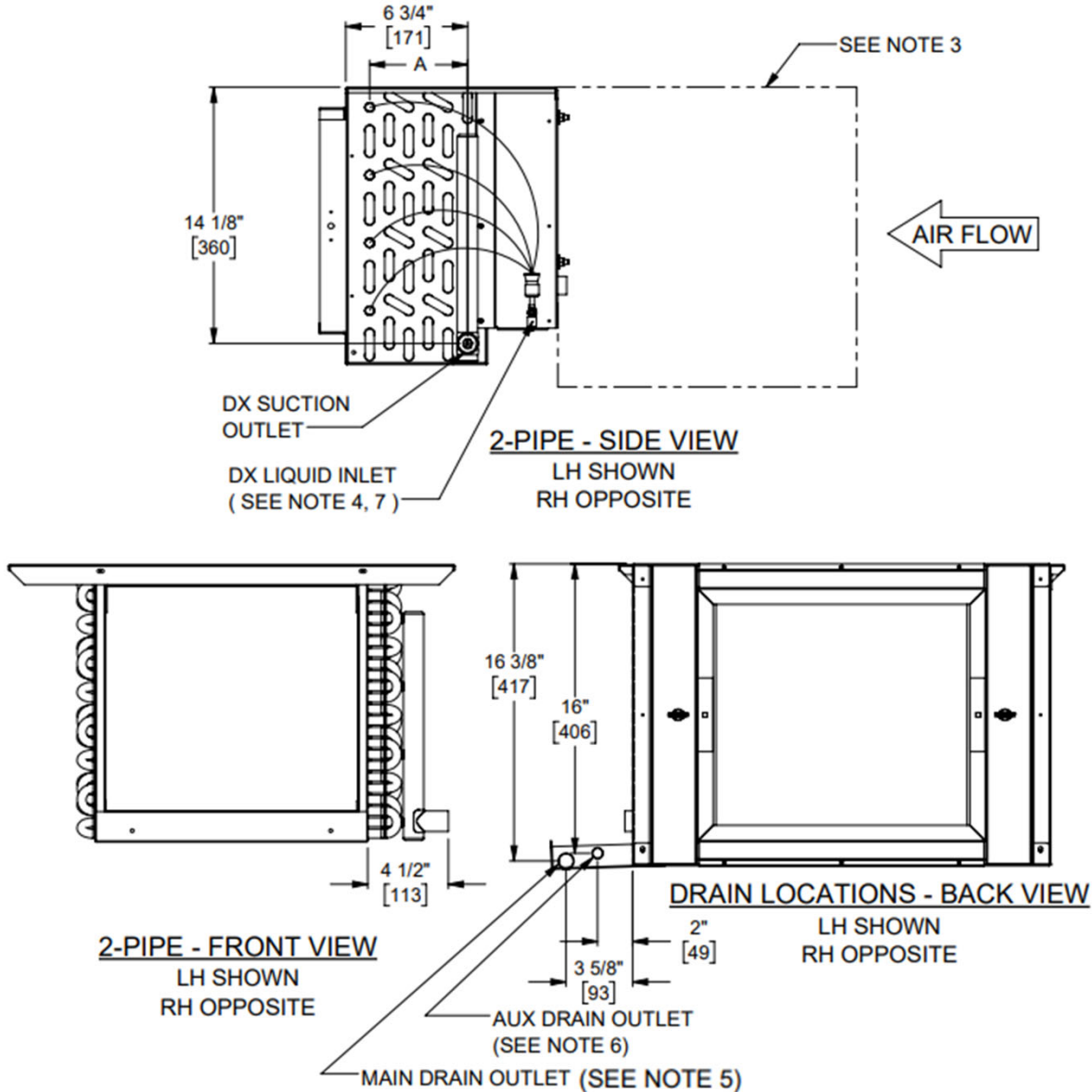

Unit Type - EH & 2 Pipe	
Coil 1 DX Rows	1/2" Coil
	A
3	2-1/8" [55]
4	3-1/4" [82]
6	5-3/8" [137]

**NOTES:**

- All dimensions are inches [millimeters]. All dimensions +/- 1/2 [13mm]. Metric values are soft conversion.
- All drawings subject to change without notice.
- Model "RAHR" unit shown, typical for model "RAHO" units. Connections shown are internal on "RAHC" units.
- Connection Size: See Page 10 Coil Connections.
- Standard externally foam coated galvanize steel drain pan has 7/8" ODM copper outlet. Stainless steel drain pan has 3/4" MPT galvanize steel outlet.
- Aux. drain outlet is 5/8" ODM copper or 3/8" MPT galvanized steel respectively.
- Liquid Inlet arrangement may vary.

**RAHR/RAHO/RAHC Series A**

Horizontal High Performance Concealed, Concealed Plenum & Exposed Coil Connections

WATER & DX COIL CONNECTION SIZES				WATER & DX COIL CONNECTION SIZES			
UNIT SIZE	TYPE	# ROWS	CONN. SIZE (OD)	UNIT SIZE	TYPE	# ROWS	CONN. SIZE (OD)
06	HW	1	5/8	14	HW	1	7/8
06	HW	2	5/8	14	HW	2	7/8
06	HW	3	7/8	14	HW	3	1 1/8
06	HW	4	7/8	14	HW	4	1 1/8
06	CW OR DX	3	7/8	14	CW OR DX	3	1 1/8
06	CW OR DX	4	7/8	14	CW OR DX	4	1 1/8
06	CW OR DX	6	7/8	14	CW OR DX	6	1 1/8
08	HW	1	5/8	16	HW	1	7/8
08	HW	2	5/8	16	HW	2	7/8
08	HW	3	7/8	16	HW	3	1 1/8
08	HW	4	7/8	16	HW	4	1 1/8
08	CW OR DX	3	7/8	16	CW OR DX	3	1 1/8
08	CW OR DX	4	7/8	16	CW OR DX	4	1 1/8
08	CW OR DX	6	7/8	16	CW OR DX	6	1 1/8
10	HW	1	5/8	18	HW	1	7/8
10	HW	2	5/8	18	HW	2	7/8
10	HW	3	7/8	18	HW	3	1 1/8
10	HW	4	7/8	18	HW	4	1 1/8
10	CW OR DX	3	7/8	18	CW OR DX	3	1 1/8
10	CW OR DX	4	7/8	18	CW OR DX	4	1 1/8
10	CW OR DX	6	7/8	18	CW OR DX	6	1 1/8
12	HW	1	5/8	20	HW	1	7/8
12	HW	2	5/8	20	HW	2	7/8
12	HW	3	7/8	20	HW	3	1 1/8
12	HW	4	7/8	20	HW	4	1 1/8
12	CW OR DX	3	7/8	20	CW OR DX	3	1 1/8
12	CW OR DX	4	7/8	20	CW OR DX	4	1 1/8
12	CW OR DX	6	7/8	20	CW OR DX	6	1 1/8

**NOTES:**

1. Tables apply to 1/2" and 3/8" tube diameters.
2. Number of circuits does not affect coil connection sizes.

**RAHO Series A**

Horizontal High Performance Concealed External Space Requirements

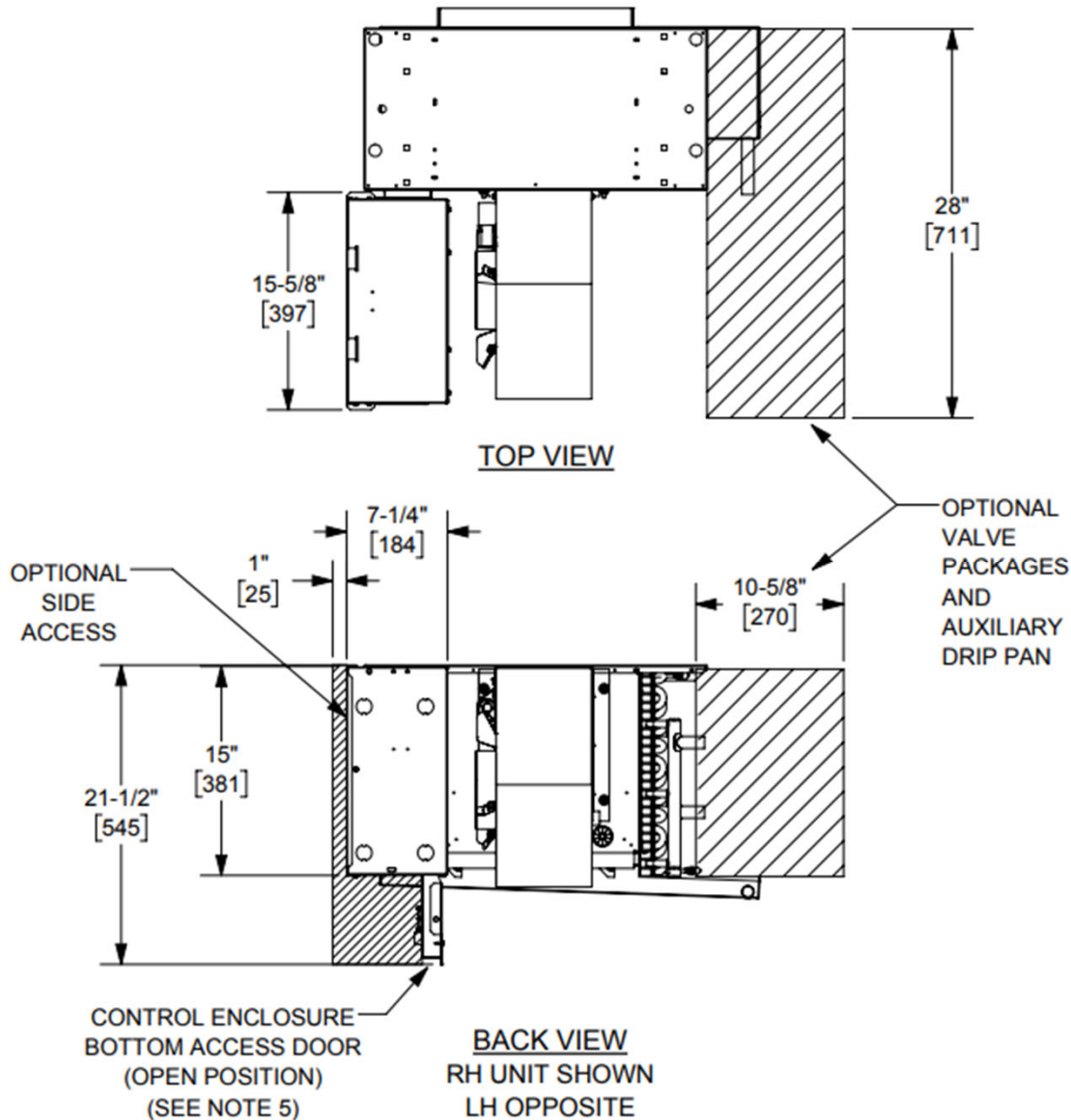

**NOTES:**

1. All chilled water piping that projects beyond the condensate pan or the optional auxiliary drip pan must be field insulated by others.
2. Optional Auxiliary Drip Pan (not shown) is mounted on the outlet side of the drain pan.
3. Drain pan is installed with the outlet tube(s) on cooling coil connection end of coil on 4-pipe units with optional opposite end connection.
4. Dimensions shown on this drawing apply to standard CW and HW valve packages. Refer to the Piping Package Catalog for valve package code details. Contact factory for details on valve packages using non-standard or customer furnished components.
5. Provide sufficient clearance to access electrical components and comply with all applicable codes and ordinances.

**RAHR/RAHO Series A**

Horizontal High Performance Concealed & Concealed Plenum (Telescoping-Filter & Solid Bottom Access Panels)

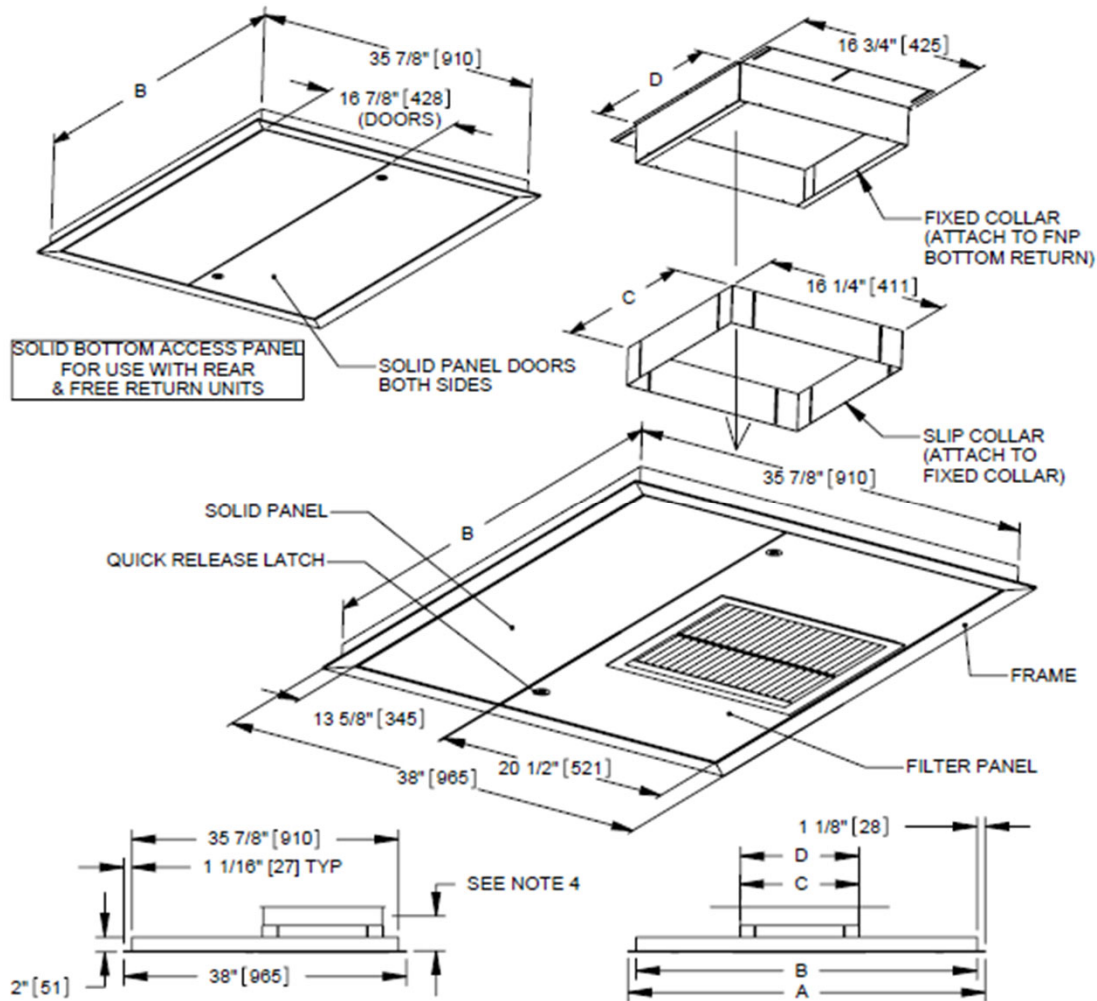

Unit Size	Dim "A"		Dim "B"		Dim "C"		Dim "D"		Recommended Ceiling Cut-Out					
	in	mm	in	mm	in	mm	in	mm	in			mm		
06	48	1219	45 7/8	1164	16	408	15 7/8	404	46 1/8	X	36 1/8	1171	X	918
08	53	1346	50 7/8	1291	20	509	19 7/8	506	51 1/8	X	36 1/8	1298	X	918
10	57	1448	54 7/8	1392	25	636	24 7/8	633	55 1/8	X	36 1/8	1400	X	918
12	62	1575	59 7/8	1519	32	814	31 7/8	811	60 1/8	X	36 1/8	1527	X	918
14	67	1702	64 7/8	1646	36	916	35 7/8	912	65 1/8	X	36 1/8	1654	X	918
16	72	1829	69 7/8	1773	40	1017	39 7/8	1014	70 1/8	X	36 1/8	1781	X	918
18	77	1956	74 7/8	1900	45	1144	44 7/8	1141	75 1/8	X	36 1/8	1908	X	918
20	81	2057	78 7/8	2002	50	1271	49 7/8	1268	79 1/8	X	36 1/8	2009	X	918

**NOTES:**

1. Telescoping/filter bottom access panel for use with bottom & free return units.
2. ALL DIMENSIONS ARE IN INCHES [mm] AND ARE +/- 1/8"
3. 1" THROWAWAY FILTER STANDARD, 1" OR 2" PLEATED FILTERS ARE OPTIONAL
4. BOTTOM PANELS ARE REMOVABLE
5. TOTAL TELESCOPING ADJUSTMENT IS 3 1/2" TO 6 1/2"
6. FILTER AND GRILLE SIZES ARE THE SAME FOR EACH UNIT SIZE IN THE THH PRODUCT LINE.